

CONSPIT CPP.LITE

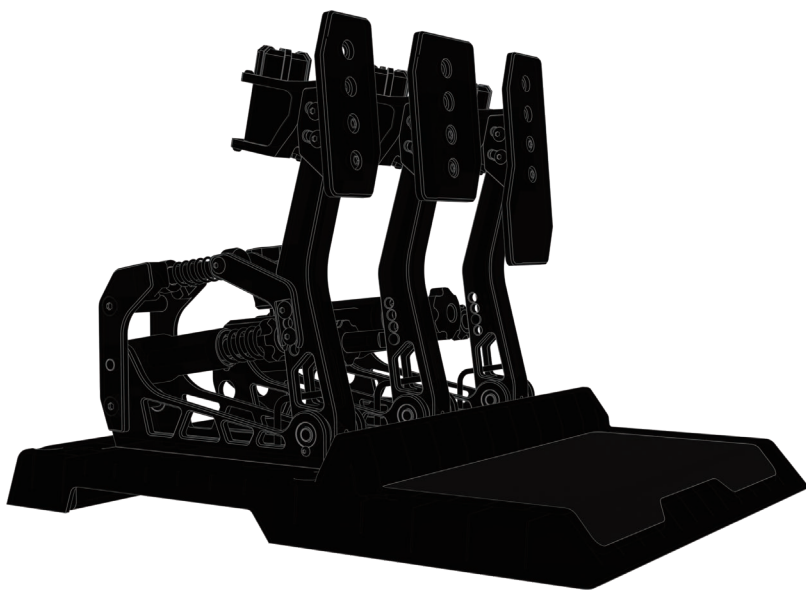

Quick Guide

Product Disclaimer	1
Packing List	3
01 Install the CPP.LITE to the Base Mounting Plate	4
1. Recommended position of pedals	4
2. Cable routing path.....	5
3. Mount the pedal set to the base mounting plate	5
4. Connect all cables	6
5. Connect the power connector and USB data cable	7
02 Install the Pedal Set to the Rig	8
1. Mount CPP.LITE to the rig	9
2. Mount CPP.LITE to Aluminum Profile-based Rig.....	10
03 Fine Tune Your CPP.LITE	11
Pedal pads angle adjustment	11
Pedal pads height adjustment.....	12
Throttle pedal feel adjustment	12
Brake pedal feel adjustment	13
Clutch pedal feel adjustment	15

Table of Contents

04 Driver Software Installation and Set-Up	16
1. Download CONSPIT_LINK.....	16
2. Settings	16

*Please note the serial number on your product before contacting the support. The serial number can be found on the inner and outer packaging, control board and warranty card, and written here for your convenience.



Product Disclaimer

We hereby reminds you that:

Before using this product, please ensure that you have carefully read and fully understood this Product Disclaimer and all the following product safety tips and operation specifications. To the extent permitted by the laws of the People's Republic of China, Ensu (Shanghai) Electronic Technology Co., Ltd. is not responsible for all personal injury and/or property damage caused by your failure to obey any of the following safety tips or operating specifications.

If you have any questions about this Disclaimer or the following product safety tips and operating specifications, you can consult through support@conspit.com. In the process of reading this Disclaimer and the following product safety tips and operating specifications, you should immediately stop using this product if you do not agree with any of the contents. If you do use this product, your behavior will be regarded as an acceptance of this Disclaimer and the following product safety tips and operation specifications.

- **It is essential to use this product under safe conditions:**

Please ensure that the user has the ability to move independently and is conscious. Do not use this product when sick, fatigued, or under the influence of alcohol/drugs.

- **Ensure proper installation of the product:**

This product requires you to complete some installation work. Make sure that all parts of the bracket are properly and securely installed. Please follow the steps and instructions in the product manual during the installation process. Using the product without proper installation may result in the following: partial fasteners coming loose and causing collision injuries, parts detaching and causing injury to yourself or others.

- **Prevent excessive use of force.**

During the design and production of this product, large structural strength and safety redundancy have been considered to prevent parts from falling off. However, improper force application beyond the normal use range may cause damage to the components, resulting in potential safety risks.

- **Situations that may pose hazards during normal use include, but are not limited to:**
 - Other people or pets coming close to the user's operating area.
 - Electrical cables near the working area of pedals, steering wheels, and other moving parts.
 - User's foot slipping off the pedal when applying force.
 - Do not use this product without shoes

- **Follow all safety tips and operating procedures:**
 - Avoid using the product for an extended period - prolonged continuous use may cause fatigue, muscle pain, or other negative effects. We recommend a maximum single-use time of 2 hours, and the daily maximum recommended usage time should not exceed 6 hours.
 - Prohibit independent use by children under 12 years old, this product is not designed for use by children. Children should use this product under the supervision of their guardian.

- **Malfunctioning and damaged products:**
 - If the product is damaged or cannot be used properly, please stop using it immediately and consult CONSPIT's after-sales customer service. Continuing to use it may cause further damage to the product.
 - Do not attempt to repair the product or its accessories by yourself.
 - CPP hydraulic brake system contains hydraulic oil. If user finds oil leakage, damage, etc., please contact customer service immediately. Unauthorized disposal of hydraulic oil may cause injury (including swallowing, slipping and other injuries).

- **General preventive measures:**
 - Please store and protect the product and its accessories properly.
 - Do not immerse the product in liquid.
 - Do not use the product in any environment with flammable substances.
 - Using the product in dusty or dirty locations may cause damage.
 - Do not drop the product (or its components) or subject it to physical impact.

Packing List



(A)
Base Mounting Plate



(B)
CPP.LITE 2
-Throttle and Brake Pedals



(B)
CPP.LITE 3
-Throttle, Brake and
Clutch Pedals



(C)
Stickers



(D)
M8x12mm
Rounded head bolts
(6 pieces)



(E)
M8x16mm
Hex bolts
(4 pieces)



(F)
Hex wrench 6.0
Hex wrench 5.0
Hex wrench 4.0



spare parts
(elastomers)

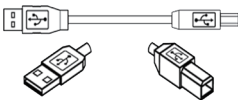

(I)
USB Cable



(J)
Power Adapter



(K)
Adjustment Tool
(Hydraulic Preload)

01 Install the CPP.LITE to the Base Mounting Plate

* Precautions during installation

- The product contains small parts. Please avoid accidental swallowing. It is forbidden to disassemble modular units such as hydraulic brake system, clutch modules.
- Avoid using excessive force to prevent screw damage and other potential risks.

Accessories required for this step

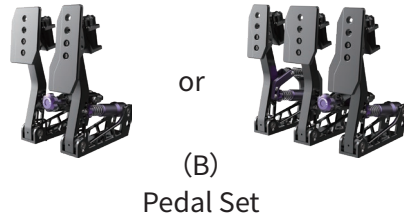

* Please flip the base mounting plate first and connect all cables (including USB cables) to the control board underneath before installing the pedal to the rig.

Installation sequence

- (1) Mount each pedal set to recommended position on the base mounting plate (A).

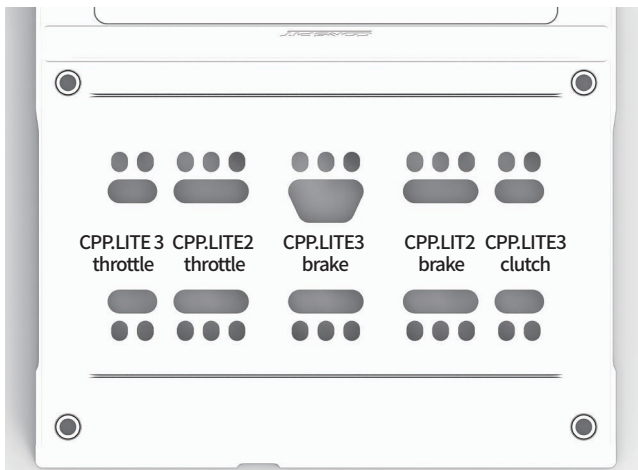

- (2) Thread all data and rumble motor cables through the lumbar hole on the base mounting plate.

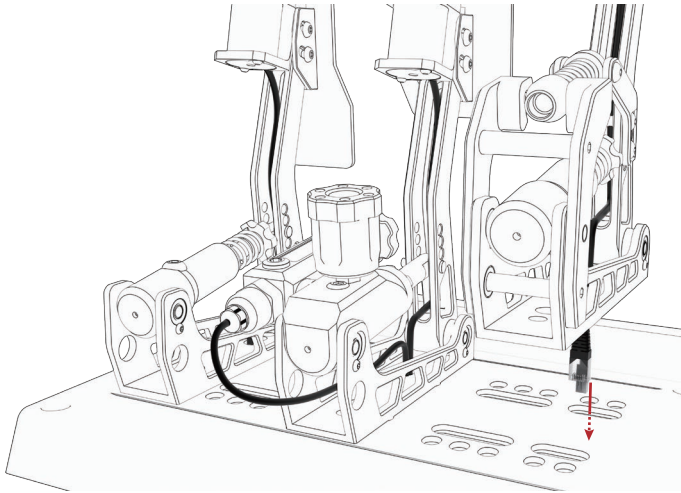

- (3) Mount the pedal set to the base mounting plate.

The figure below takes the throttle pedal as an example
The brake and clutch pedals are installed in the same way

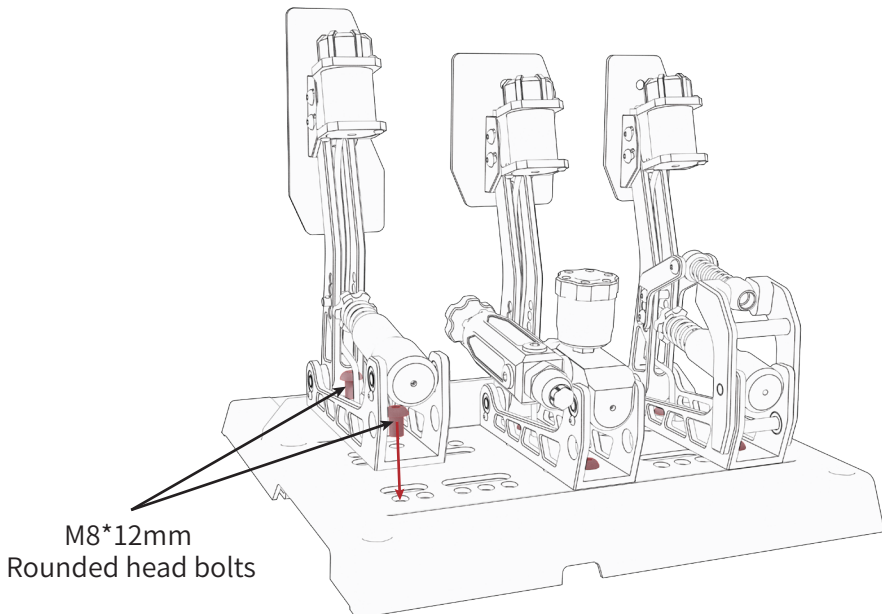

(4) Flip the base mounting plate to the bottom side and connect all cables shown as below.

* In order to ensure the stability of data transmission, the data cable must be ensured no entanglement or crushing during assemble.

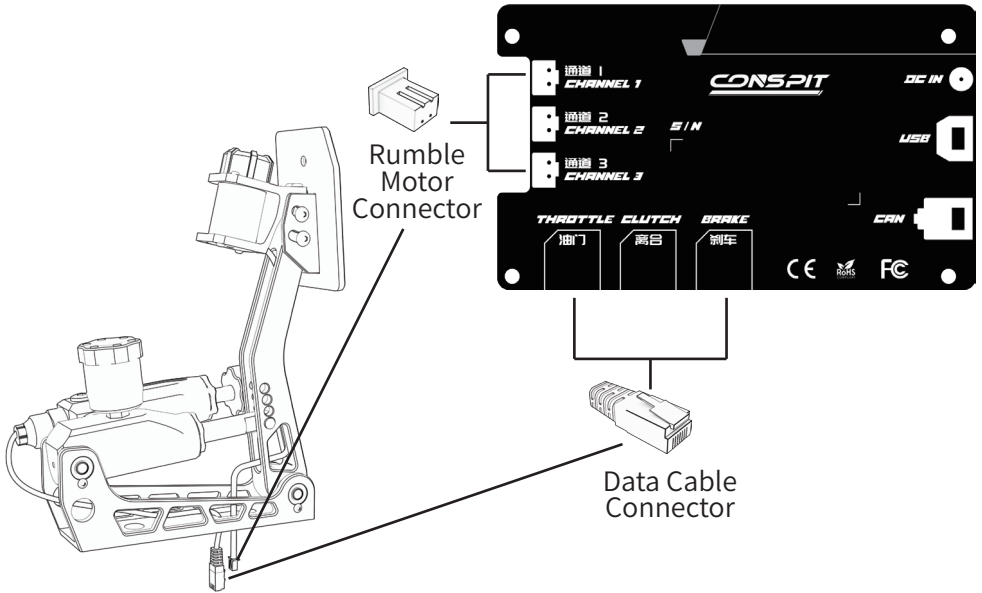

Connection Demonstration

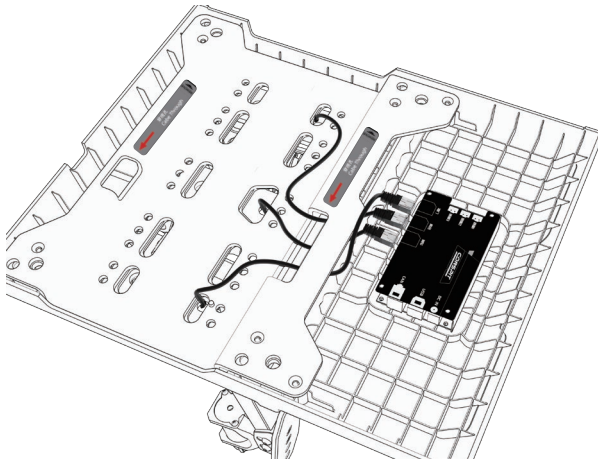

Data Cable Connection

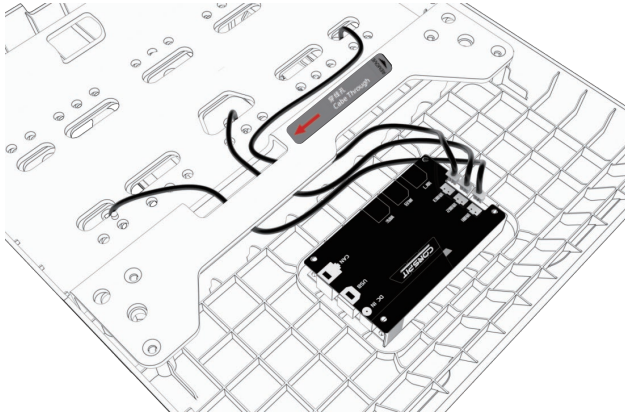

Rumble Motor Connection

Note: The rumble motor channels are interchangeable. To ensure compatibility with SimHub vibration, please follow the wiring diagram sequence.

- (5) Connect the power connector and USB data cable to the control board through the openings reserved for passing wire.

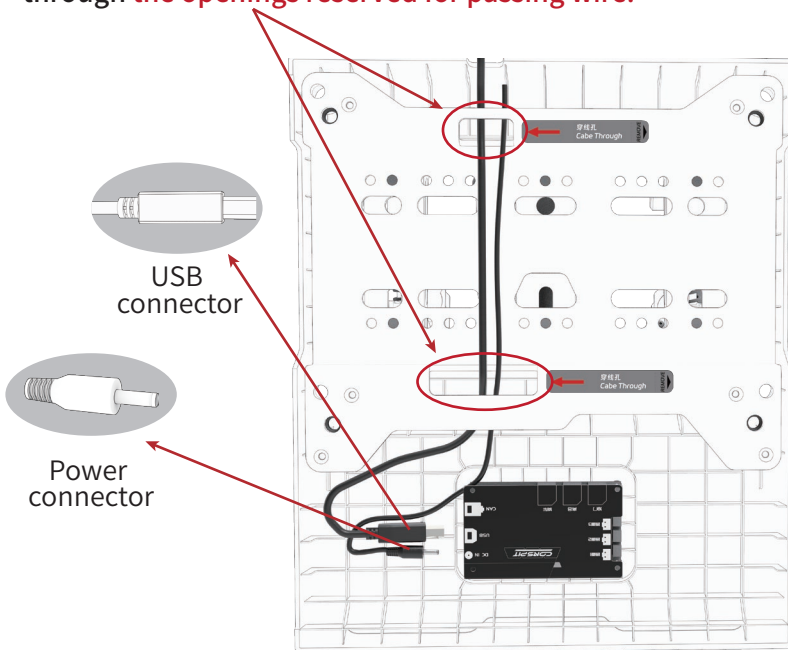

Power and USB Connection

02 Install the Pedal Set to the Rig

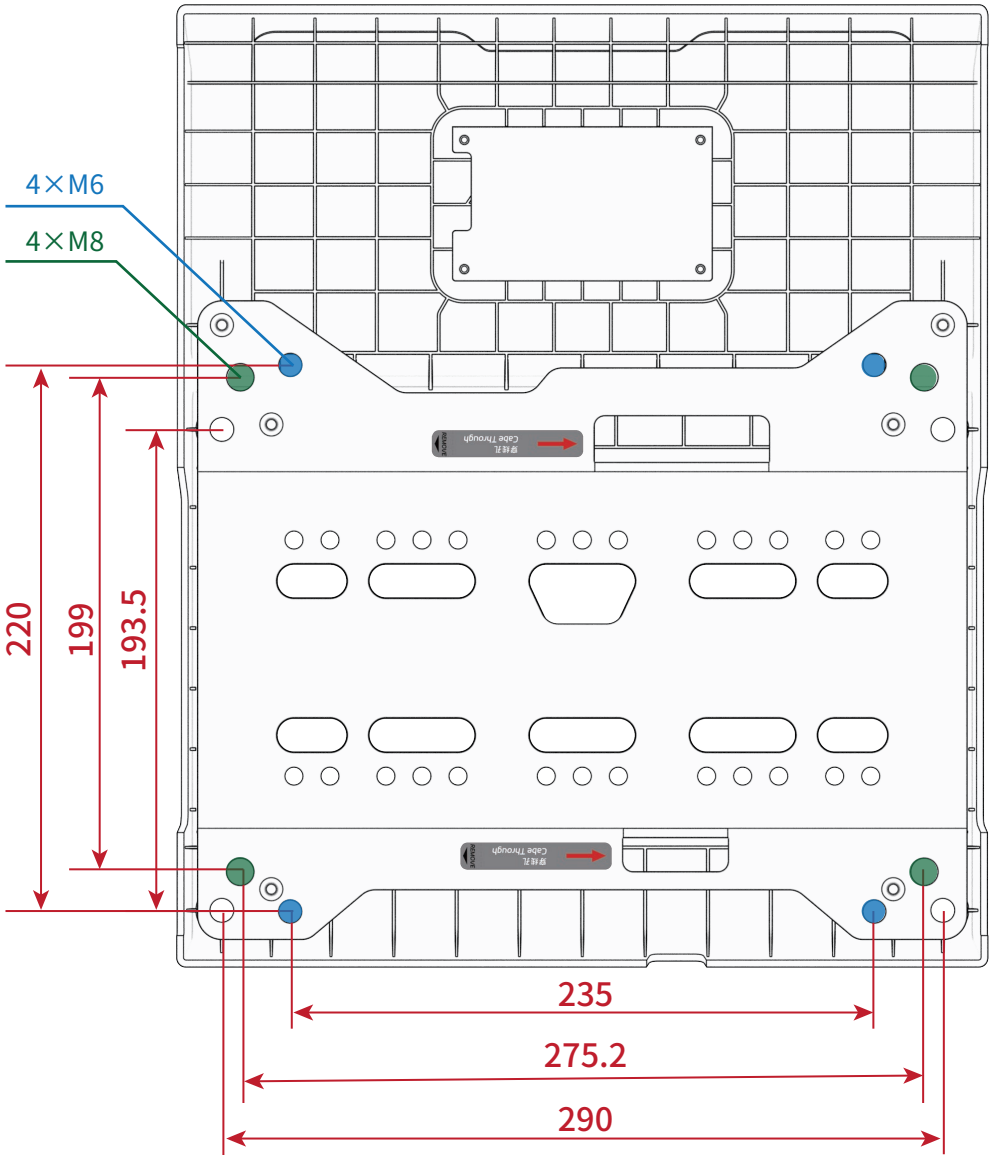

CPP.LITE Drilling Template

(1) Mount CPP.LITE to the rig

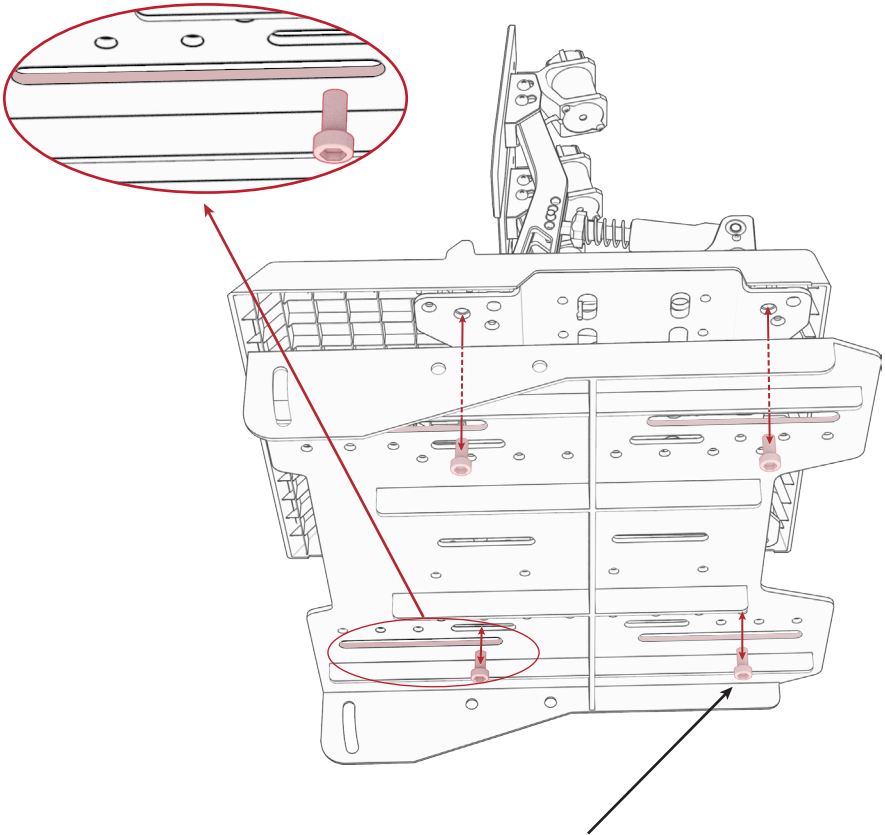

M8*16mm hex bolts (4 pieces)

(2) Mount CPP.LITE to Aluminum Profile-based Rig

40 Series T-Slot Aluminum Profile is recommended

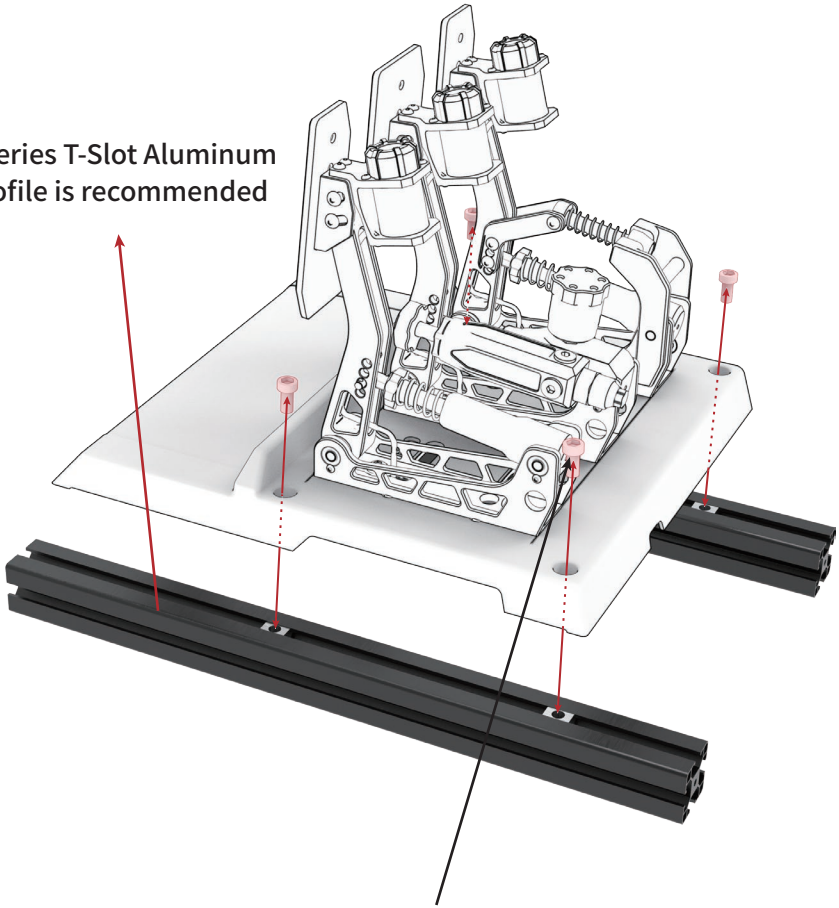

M8*16mm hex bolts (4 pieces)

CPP series provides versatile adjustable space, with throttle, brake, and clutch supporting stepwise force adjustment as well as further fine-tuning without limitations.

- **Pedal Pads Angle Adjustment**

The angle adjustment range of the pad is 0° to 15° , with 0° being when the plate is perpendicular to the pedal base.

***Angle recommendation:**

- Formula posture: $0^{\circ}\sim 5^{\circ}$
- GT posture: $5^{\circ}\sim 15^{\circ}$

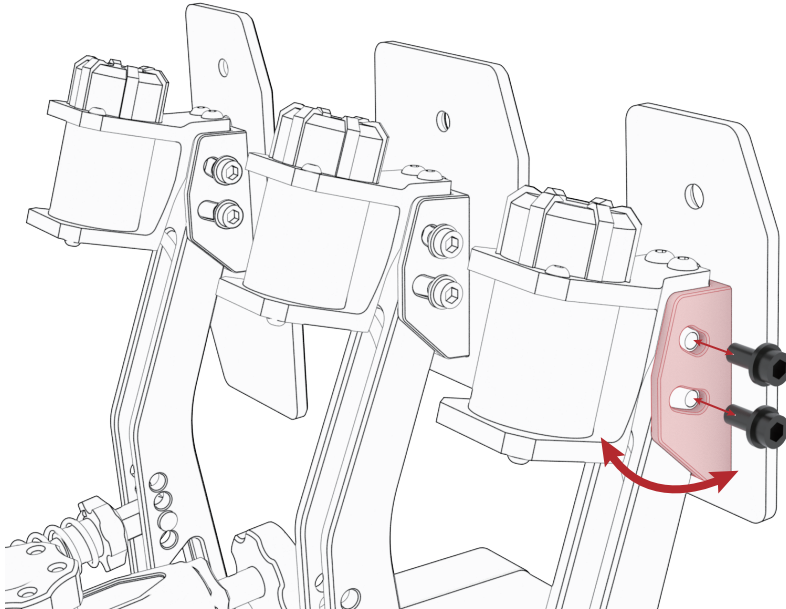

- Pedal Pads Height Adjustment

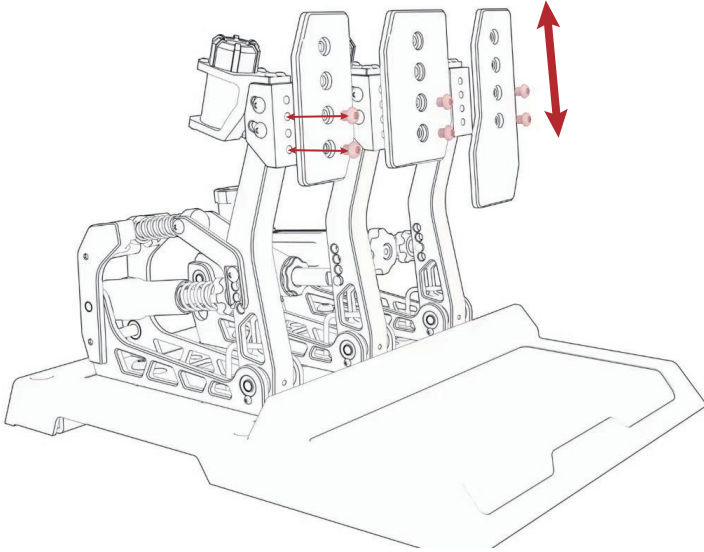

- Throttle Pedal Feel Adjustment

Different pedal force can be adjusted by changing the locking pin position. The pedal force varies with the corresponding position. Pedal force increases sequentially from bottom to top.

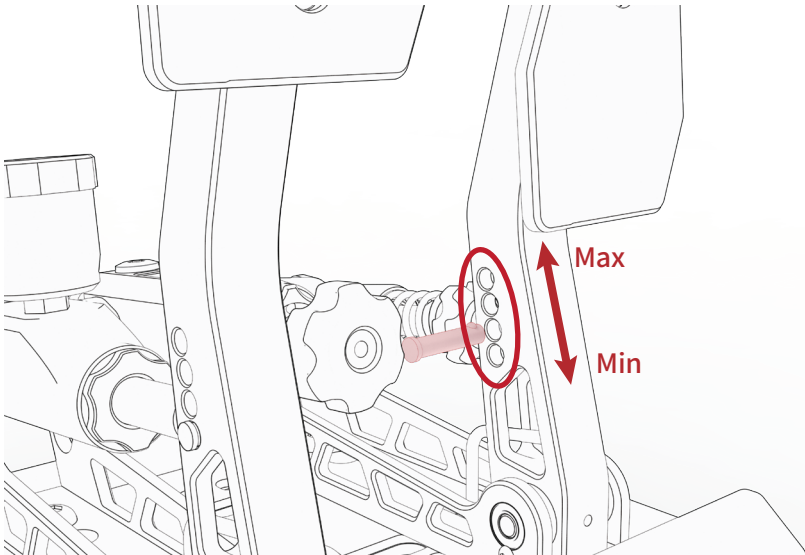

Pedal force and travel can be further fine-tuned by turning the knob.

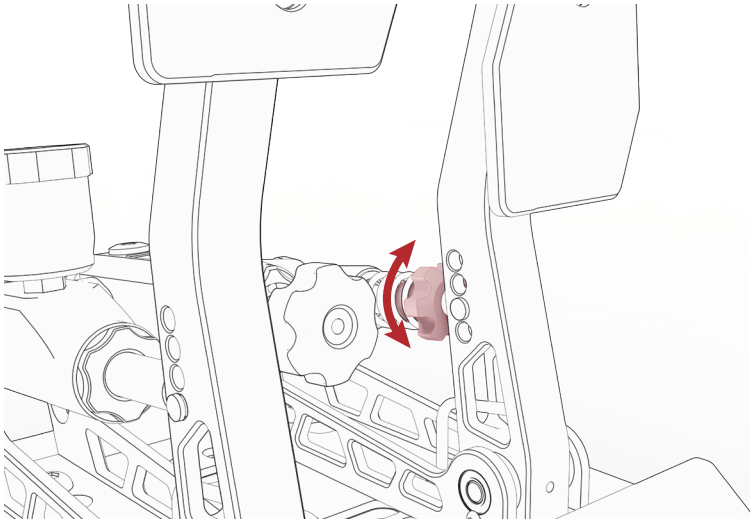

• **Brake Pedal Feel Adjustment**

By changing the locking pin position, the pedal force can be stepped change.

1. Turn the knob counter-clockwise to completely release the preload pressure

2. Press the brake pedal 1~2 times

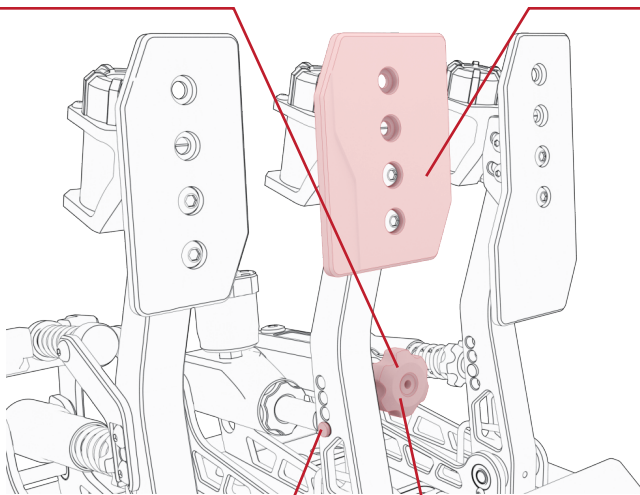

3. Change the locking pin position

4. Turn the knob clockwise to desired hydraulic preload

The four positions of the locking pin simulate different brake pedal feel of various vehicles. When the hydraulic sensor reaches its maximum capacity (100 bar), the corresponding pedal force on the pedal pad is shown in the table below:

Type	Pedal Force
• Formula Racing Car	800N
• GT Racing Car	688N
• Hyper Car	556N
• Sports Car	430N

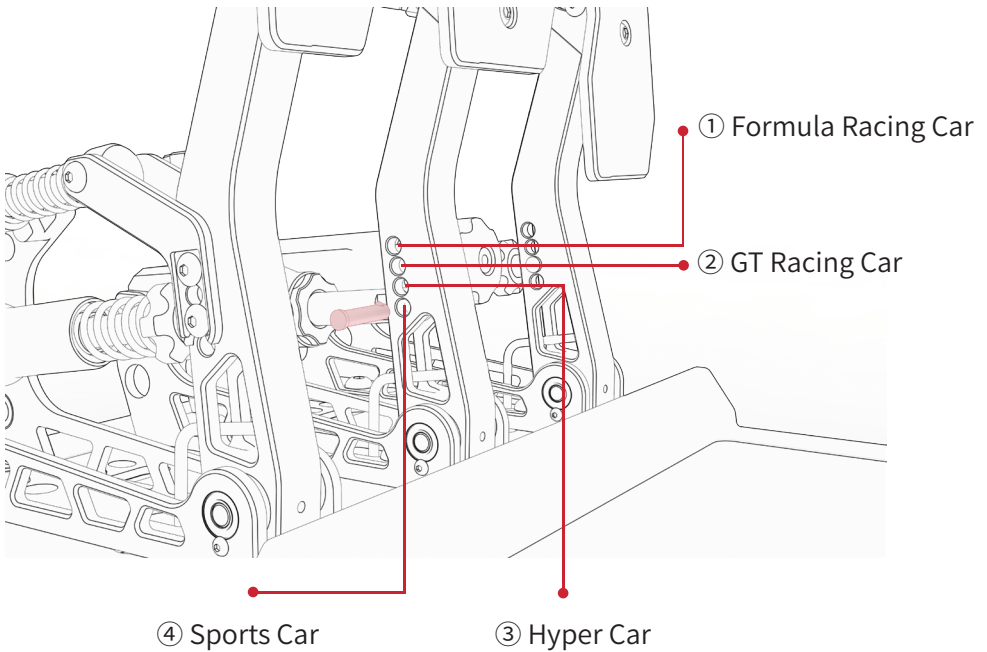

Hydraulic Preload of the brake can be adjusted by turning the knob with the adjustment tool.

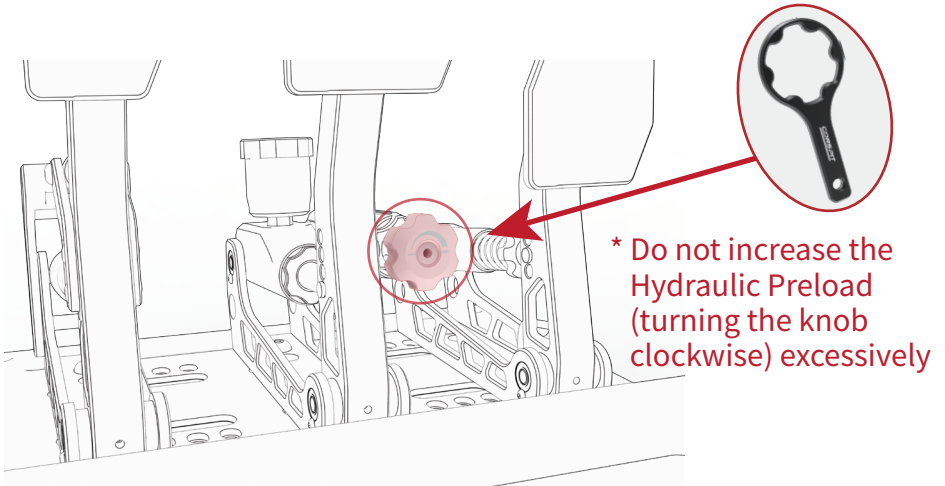

- **Clutch Pedal Feel Adjustment**

The clutch travel and engagement point can be adjusted by turning the knob.

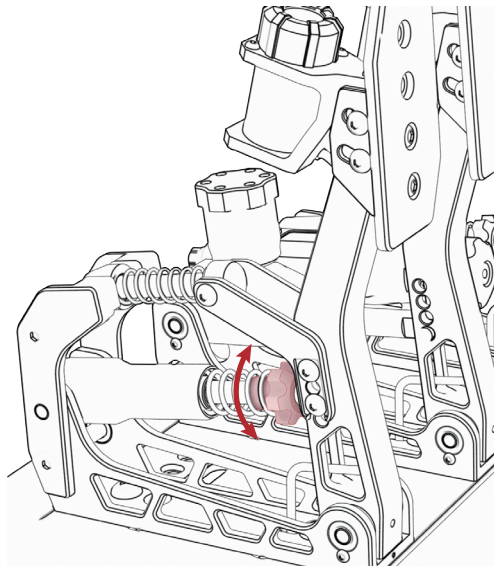

04 Driver Software Installation and Set-Up

- (1) Visit www.conspit.com and download CONSPIT_LINK.
- (2) Access the pedals settings page

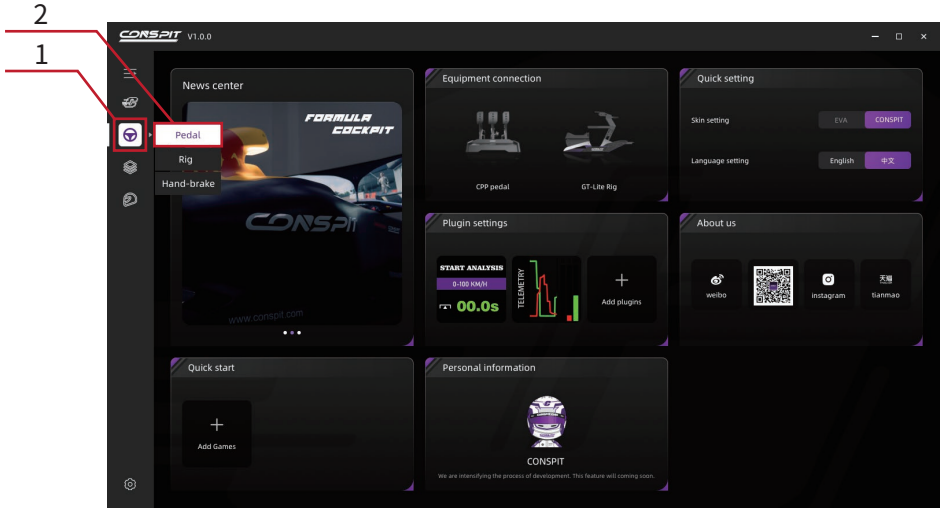

(3) Calibration of the pedals

- 2. Click "Min" to calibrate the minimum value when the pedal is completely released.
- 3. Click "Max" to calibrate the maximum value when the pedal is fully pressed.

1. Select the pedal to be adjusted.

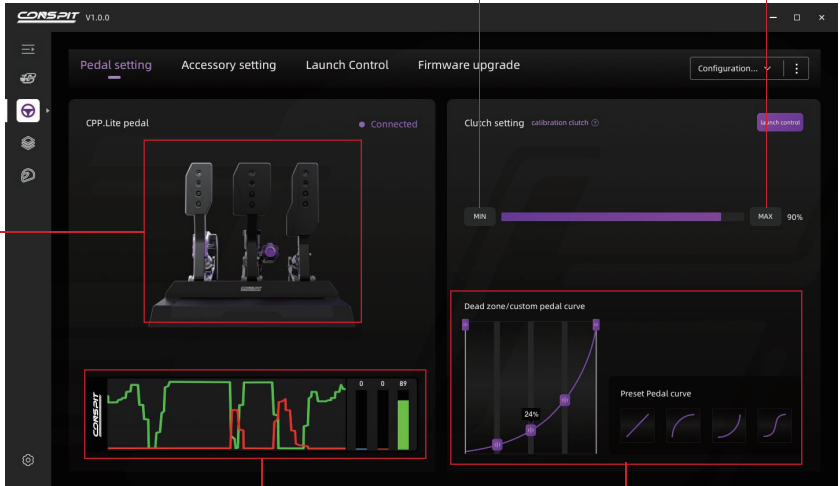

Time-Pedal Travel Curve

Custom Mapping Curve

CONSPIT